



Since 1971

HAMBURGATRICI PATTY FORMER MACHINES



F 2000 SD
HD 4000 SD

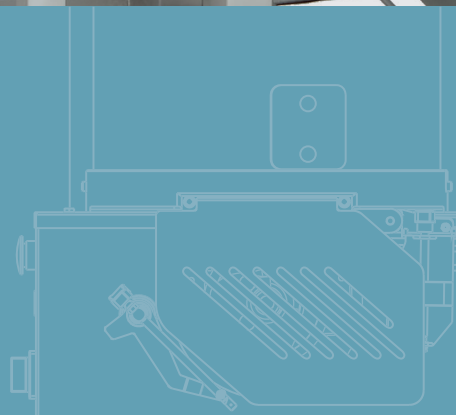



F 2000 SD

Hamburgatrice
Patty former machine



CARATTERISTICHE

- Produzione variabile da 800 a 3600 pz/h
- Funzionamento automatico o modalità impilabile fino a 5 pezzi
- Stampo rotondo singolo incluso da 100 a 130 mm
- Spessore stampo regolabile fino a 32 mm
- Contenitore 30 lt
- Nastro uscita 900 mm
- Interfogliatore
- Pulitore pneumatico integrato
- Carrello supporto con ruote

OPTIONAL

- Contenitore 40 lt

FEATURES

- Variable productivity from 800 to 3600 pcs/h
- Fonctionnement continuellement ou stacking up to 5 burgers
- Single round drum included from 100 to 130 mm
- Patty thickness adjustable to 32 mm
- Hopper 30 lt
- Conveyor belt 900 mm
- Paper attachment
- Pneumatic wire cleaner
- Support table with wheels

OPTIONAL

- Hopper 40 lt

SPECIFICHE TECNICHE / TECHNICAL SPECIFICATION

Motore	Motor	Std (kw 0,75 tr)
Diametro foglio carta	Paper dimension	114 x 114 mm / 135 x 135 mm
Diam. Max ottenibile stampo singolo circolare	Shape - max diam - single shape	130 mm
Peso netto	Net weight	150 kg
Peso imballato	Packed weight	275 kg
Dimensioni imballo legno	Wooden crate	180 x 110 x 180 cm



HD 4000 SD

Hamburgatrice
Patty former machine



CARATTERISTICHE

- Produzione variabile da 800 a 4000 pz/h
- Funzionamento automatico o modalità impilabile fino a 5 pezzi
- Stampo rotondo singolo incluso da 100 a 130 mm
- Spessore stampo regolabile fino a 32 mm
- Contenitore 20 lt
- Vasca complementare - 80 lt
- Nastro uscita 1220 mm
- Interfogliatore
- Pulitore pneumatico integrato
- Carrello supporto con ruote

FEATURES

- Variable productivity from 800 to 4000 pcs/h
- Fonctionnement continuellement ou stacking up to 5 burgers
- Single round drum included from 100 to 130mm
- Patty thickness adjustable to 32 mm
- Hopper 20 lt
- Complementary hopper - 80 lt
- Conveyor belt 1220 mm
- Paper attachment
- Pneumatic wire cleaner
- Support table with wheels

SPECIFICHE TECNICHE / TECHNICAL SPECIFICATION

Motore	Motor	Std (kw 0,75 tr)
Diametro foglio carta	Paper dimension	114 x 114 mm / 135 x 135 mm
Diam. Max ottenibile stampo singolo circolare	Shape - max diam - single shape	130 mm
Peso netto	Net weight	250 kg
Peso imballato	Packed weight	400 kg
Dimensioni imballo legno	Wooden crate	150 x 140 x 171 cm

F 2000 SD

DIMENSIONI | DIMENSIONS

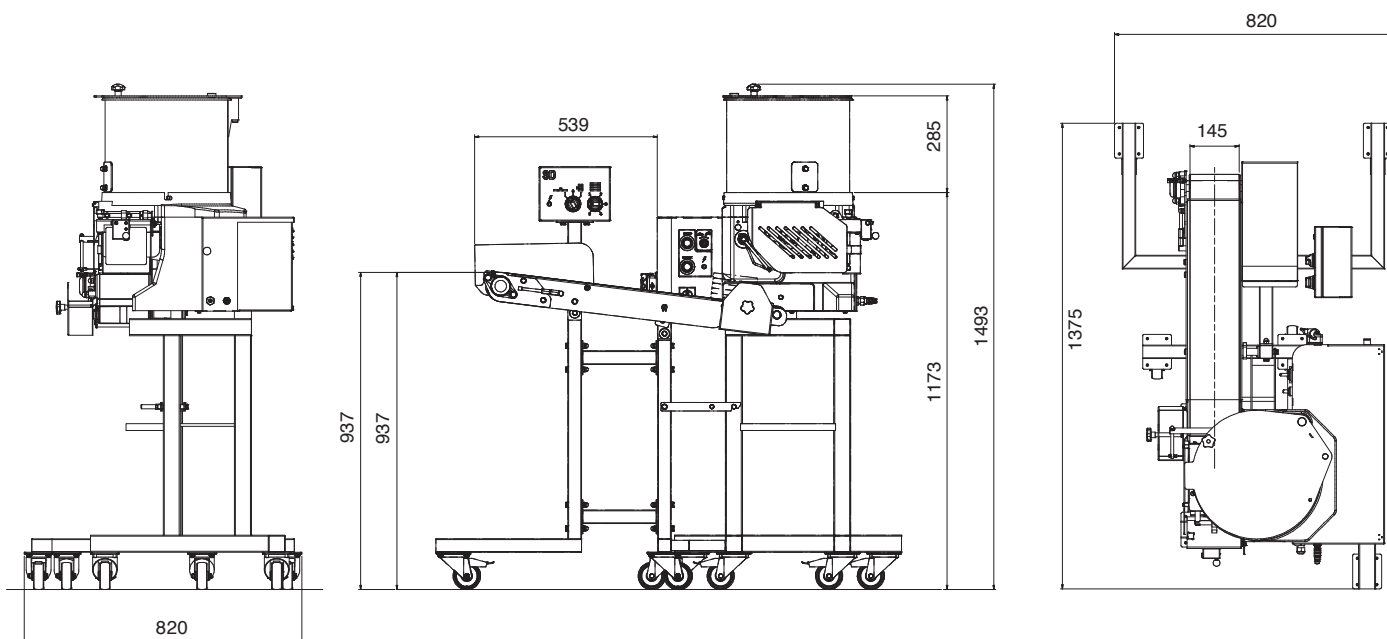

HD 4000 SD

DIMENSIONI | DIMENSIONS

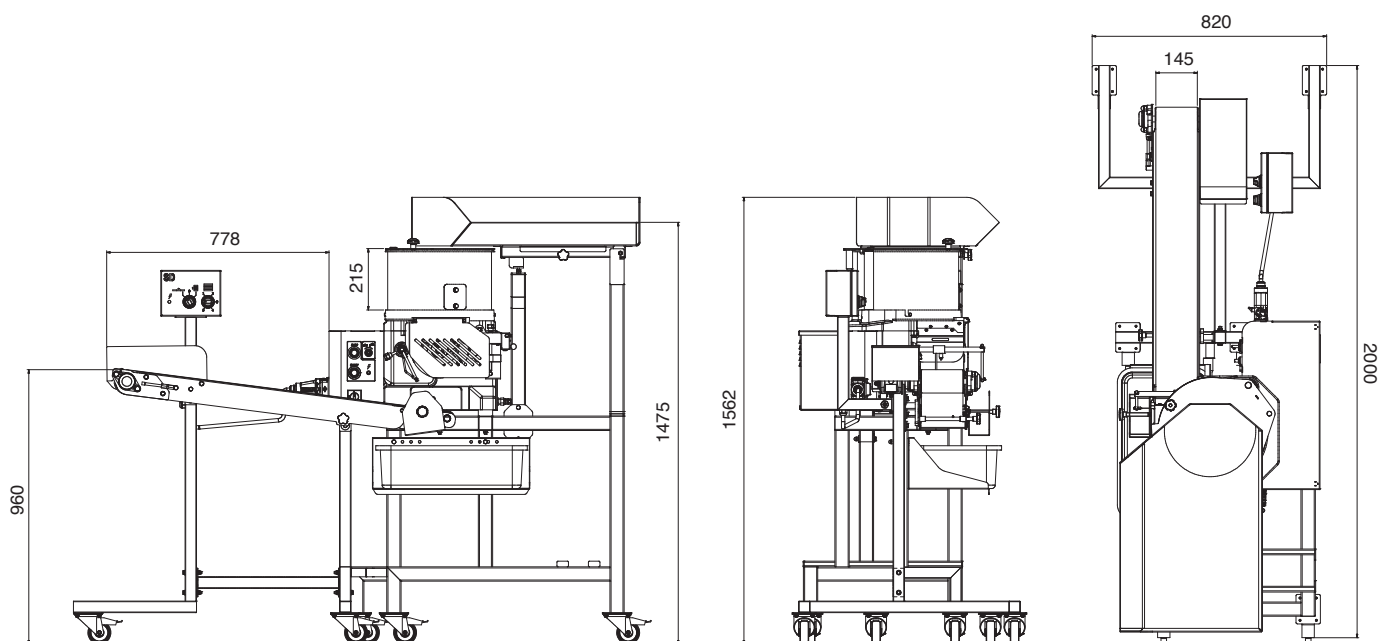

Since 1971

ITALIA - Via Rho, 6 - 20045 Lainate (Mi) - Italy
 T. +39 02 9373781 - F. +39 02 93790148 - abm@abmcompany.com
www.abmcompany.com

